

## Description

The DL0504S1-T3B0 is a 2-line ultra-low capacitance TVS diode array, utilizing leading monolithic silicon technology to provide fast response time and low ESD clamping voltage, making this device an ideal solution for protecting voltage sensitive high-speed data lines. The DL0504S1-T3B0 has a very low capacitance with a typical value at 0.3pF, and complies with the IEC 61000-4-2(ESD) standard with  $\pm 15\text{kV}$  air and  $\pm 15\text{kV}$  contact discharge. It is assembled into a lead-free SOT-143 package. The small size, very low capacitance and high ESD surge protection make DL0504S1-T3B0 an ideal choice to protect cell phone, digital video interfaces, high speed data ports, and many other portable applications.

## Mechanical Characteristics

- ◆ Package: SOT-143
- ◆ Lead Finish: Matte Tin
- ◆ Case Material: "Green" Molding Compound.
- ◆ UL Flammability Classification Rating 94V-0
- ◆ Moisture Sensitivity: Level 3 per J-STD-020
- ◆ Terminal Connections: See Diagram Below
- ◆ Marking Information: See Below

## Dimensions and Pin Configuration

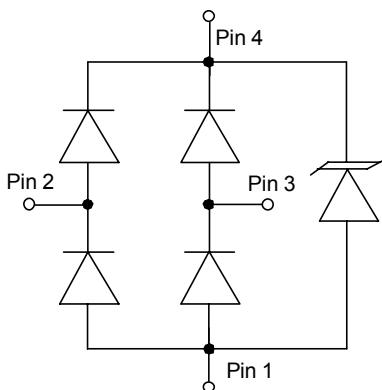

Circuit Diagram

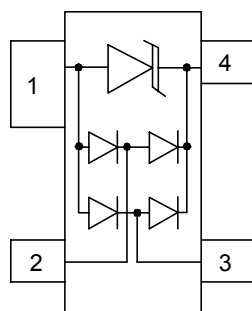

Pin Schematic

## Ordering Information

Part Number	Marking	Packaging	Reel Size
DL0504S1-T3B0	R05	3000/Tape & Reel	7 inch

## Features

- ◆ Ultra low capacitance: 0.3pF typical
- ◆ Ultra low leakage: nA level
- ◆ Operating voltage: 5V
- ◆ Low clamping voltage
- ◆ 4-pin SOT-143 package
- ◆ Protects two data lines and one power line
- ◆ Complies with following standards:
  - IEC 61000-4-2 (ESD) immunity test  
Air discharge:  $\pm 15\text{kV}$   
Contact discharge:  $\pm 15\text{kV}$
  - IEC61000-4-4 (EFT) 40A (5/50ns)
  - IEC61000-4-5 (Lightning) 2.5A (8/20 $\mu\text{s}$ )
- ◆ RoHS Compliant

## Applications

- ◆ Cellular Handsets and Accessories
- ◆ Notebooks and Handhelds
- ◆ Personal Digital Assistants
- ◆ Portable Instrumentation
- ◆ Digital Cameras
- ◆ Peripherals
- ◆ Audio Players, Keypads, Side Keys, LCD
- ◆ USB 2.0

## Marking Information

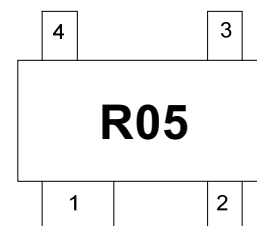

### **Absolute Maximum Ratings ( $T_A=25^{\circ}\text{C}$ unless otherwise specified)**

Parameter	Symbol	Value	Unit
Peak Pulse Power(8/20 $\mu\text{s}$ )	Ppk	40	W
Peak Pulse Current(8/20 $\mu\text{s}$ )	I <sub>PP</sub>	2.5	A
ESD per IEC 61000-4-2 (Air)	V <sub>ESD</sub>	$\pm 15$	kV
ESD per IEC 61000-4-2 (Contact)		$\pm 15$	
Operating Temperature Range	T <sub>J</sub>	-55 to +125	$^{\circ}\text{C}$
Storage Temperature Range	T <sub>stg</sub>	-55 to +150	$^{\circ}\text{C}$

### **Electrical Characteristics ( $T_A=25^{\circ}\text{C}$ unless otherwise specified)**

Parameter	Symbol	Min	Typ	Max	Unit	Test Condition
Reverse Working Voltage	V <sub>RWM</sub>			5	V	Any I/O pin to ground
Breakdown Voltage	V <sub>BR</sub>	6			V	I <sub>T</sub> = 1mA, any I/O pin to ground
Reverse Leakage Current	I <sub>R</sub>			0.5	$\mu\text{A}$	V <sub>RWM</sub> = 5V, any I/O pin to ground
Clamping Voltage	V <sub>C</sub>			9	V	I <sub>PP</sub> = 1A (8 x 20 $\mu\text{s}$ pulse), any I/O pin to ground
Clamping Voltage	V <sub>C</sub>			16	V	I <sub>PP</sub> = 2.5A (8 x 20 $\mu\text{s}$ pulse), any I/O pin to ground
Junction Capacitance	C <sub>J</sub>		0.3	0.4	pF	V <sub>R</sub> = 0V, f = 1MHz, between I/O pins
Junction Capacitance	C <sub>J</sub>			0.8	pF	V <sub>R</sub> = 0V, f = 1MHz, any I/O pin to ground

Note 1: I/O pins are pin 2&3

**Typical Performance Characteristics (TA=25°C unless otherwise Specified)**

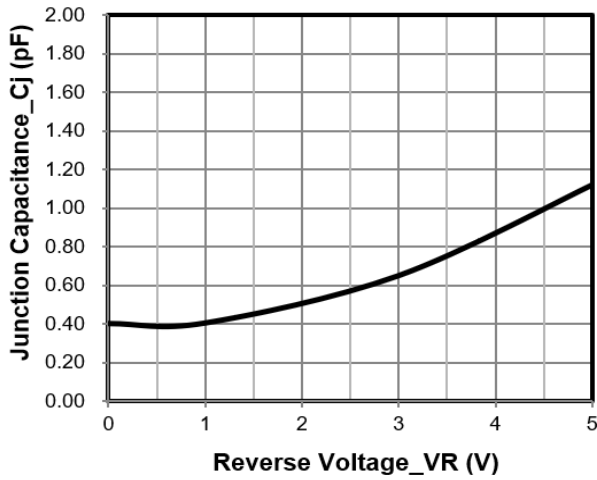

Junction Capacitance vs. Reverse Voltage

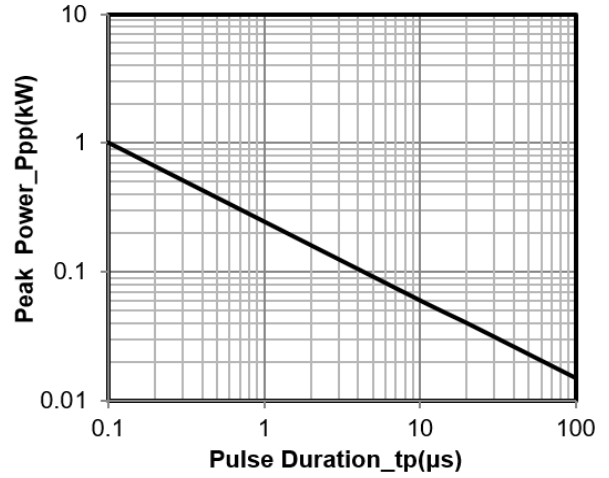

Peak Pulse Power vs. Pulse Time

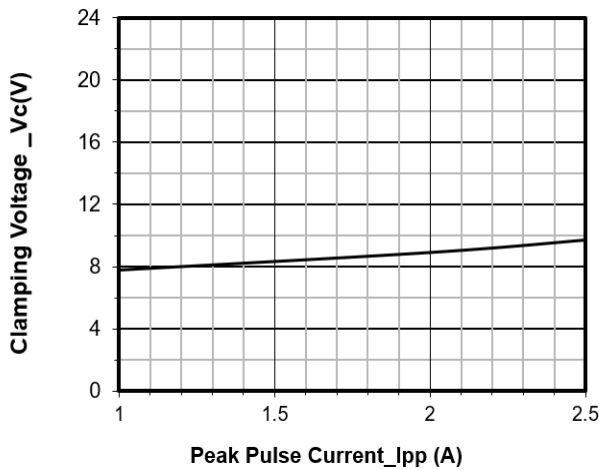

Clamping Voltage vs. Peak Pulse Current

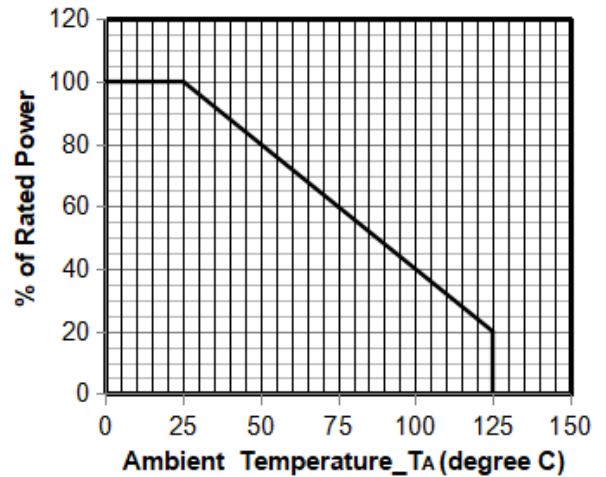

Power Derating Curve

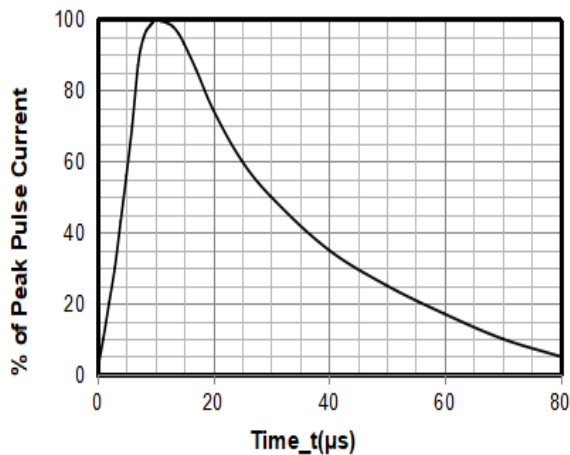

8 X 20μs Pulse Waveform

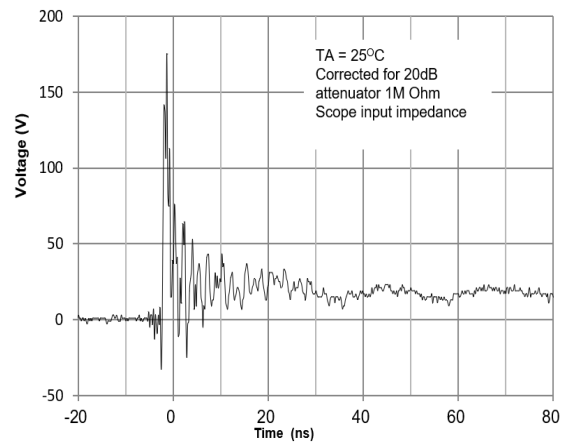

ESD Clamping Voltage  
8 kV Contact per IEC61000-4-2

## DL0504S1-T3B0 on USB Port Application

The DL0504S1-T3B0 tvs can be used to protect the USB port on the monitors, computers, peripherals or portable systems. The ESD protection scheme for single USB ports is shown below figure ,the voltage bus(VBUS) of USB port is connected to the power pin (pin4) of tvs DL0504S1-T3B0. Each data line (D+/D-) of USB port is connected to the ESD protection pin (pin2/pin3) of tvs DL0504S1-T3B0. When ESD voltage pulse appears on the data line, the ESD pulse current will be conducted by tvs DL0504S1-T3B0 away from the USB controller chip. In addition, the ESD pulse current also can be conducted by tvs DL0504S1-T3B0 away from the USB controller chip when the ESD voltage pulse appears on the voltage bus (VBUS) of USB port. Therefore, the data lines (D+/D-) and voltage bus (VBUS) of two USB ports are complementally protected with one DL0504S1-T3B0.

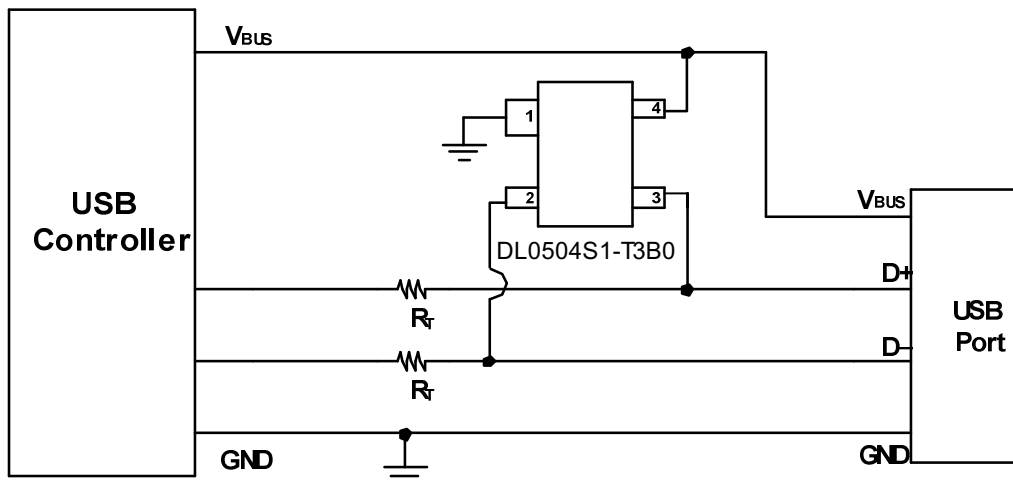

### SOT-143 Package Outline Drawing

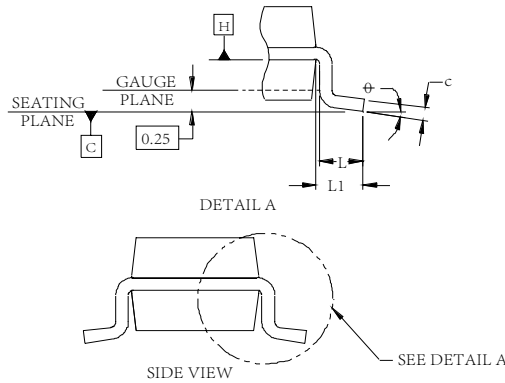
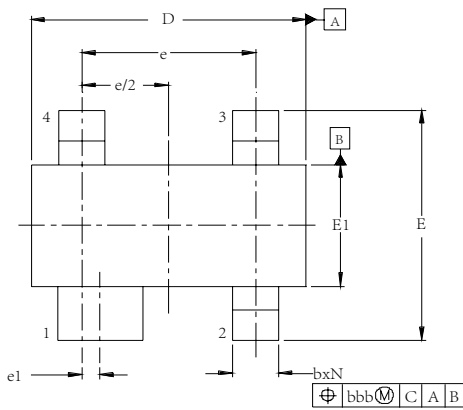

DIM	DIMENSIONS					
	INCHES			MILLIMETERS		
	MIN	NOM	MAX	MIN	NOM	MAX
A	.031	-	.048	0.80	-	1.22
A1	.000	-	.006	0.013	-	0.15
A2	.029	.035	.042	0.75	0.90	1.07
b	.011	-	.020	0.30	-	0.51
b1	.029	-	.037	0.76	-	0.94
c	.003	-	.008	0.08	-	0.20
D	.110	.114	.120	2.80	2.90	3.04
E	.082	.093	.104	2.10	2.37	2.64
E1	.047	.051	.055	1.20	1.30	1.40
e	.075			1.92 BSC		
e1	.008			0.20 BSC		
L	.015	.020	.024	0.40	0.50	0.60
L1	(0.021)			(0.54)		
N	4			4		
phi	0°	-	8°	0°	-	8°
aaa	.006			0.15		
bb b	.008			0.20		
ccc	.004			0.10		

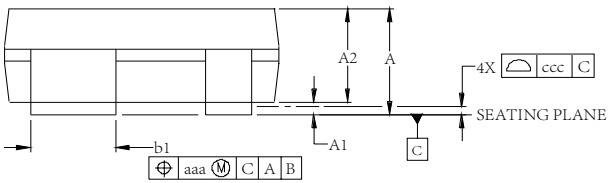

### Suggested Land Pattern

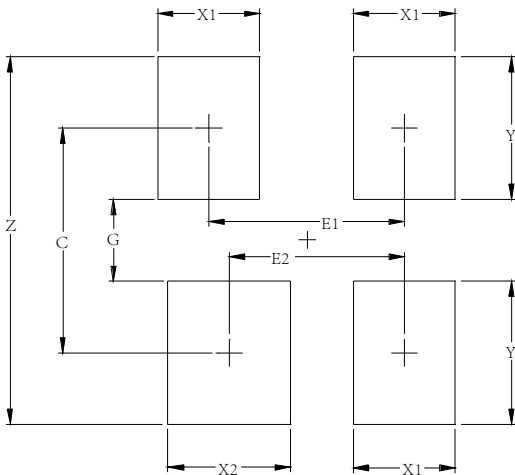

SYM	DIMENSIONS	
	MILLIMETERS	INCHES
C	2.20	0.087
E1	1.92	0.076
E2	1.72	0.068
G	0.80	0.031
X1	1.00	0.039
X2	1.20	0.047
Y	1.40	0.055
Z	3.60	0.141

### Contact Information

Changzhou D-first Electronics CO.,Ltd.  
 www.first-electronic.com  
 Email: xhf@first-electronic.cn  
 Phone: +86 (0519) 8817 1671